

User Manual

Body Scale

ESSENCE

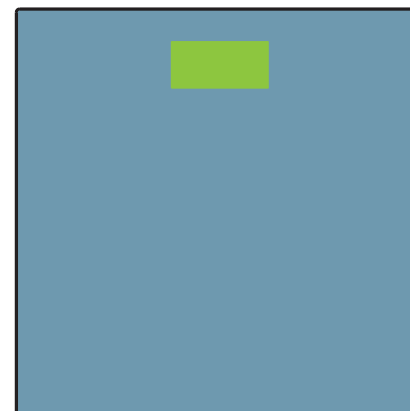

Optima Home Scales

PO Box 1526, Cumming GA 30028, United States

T:888-688-4833 www.optimahomescales.com







- Thank you very much for purchasing the OHS Body Scale ESSENCE.
- Please read the user manual carefully and thoroughly to ensure the safe usage of this product and keep the manual for further reference in case you have problems.

Table of Contents

Safety Information	
Safety and Usage Information.....	2
Your Scale and Its Environment.....	3
Efficient Use of Your Scale	3
Overview	
General Instructions.....	4
Device Components.....	4
Function Indication	4
List.....	5
LCD Display.....	5
Initial Start-Up	
Take out the Insulating Strip.....	6
Replace the Battery	6
Start Measuring	
Select Measurement Unit.....	7
Initializing Your Scale	8
Start Measuring.....	8
Troubleshooting	
Error Prompt.....	9
Specifications.....	10
Maintenance	11
Warranty.....	11
Appendix	
EMC Guidance.....	12

♥ Safety and Usage Information

The warning signs and symbols are essential to ensure your correct and safe use of this product and protect you and others from injury. Please kindly find the meanings of the warning signs and symbols, which you may encounter in the label and user manual, as follows:

	Symbol for "THE OPERATION GUIDE MUST BE READ"		Symbol for "MANUFACTURER"
	Symbol for "DIRECT CURRENT"		Symbol for "ENVIRONMENT PROTECTION – Waste electrical products should not be disposed of with household waste. Please recycle where facilities exist. Check with your local authority or retailer for recycling advice"
	Symbol for "COMPLIES WITH EU REQUIREMENTS"		
	Symbol for "SERIAL NUMBER"		

♥ Your Scale and Its Environment

To ensure your safety as well as the service life of your scale, please avoid using the scale under the following circumstances:

- Slippery floor such as tile floor
- Jumping onto the platform immediately after bath or with wet feet
- Near a cell phone or microwave oven

Avoid storage in the following locations:

- Where there is water
- Where the device may be exposed to extreme temperatures, humidity, moisture, direct sunlight, dust, or salt air
- Where there is risk of shock or drop
- Where you store chemicals or full of corrosive gases
- Where in reach of the infants or children

♥ Efficient Use of Your Scale

To ensure the accuracy of measurement, please follow below instructions when you start measurement.

- Place the scale on a flat, hard surface. Soft surface such as carpet will affect the performance of the scale.
- Start measurement at least two hours after Getting up or Dining.
- Avoid measurement immediately after strenuous exercise, sauna or bath, drinking, and dining.
- Always start measurement in the same time slot and on the same scale located on the same flat, hard surface.
- To ensure the accuracy of weighing, when you moved the scale or haven't used the scale for a long time, please turn on the scale first, wait until it turns off, then you can stand on the platform again and measure your weight.
- When you don't use the scale, please place it stable. Do not put anything on it.
- Any information provided by this scale is in no way meant to treat, cure or prevent any disease or illness from happening. If in doubt, contact your physician.
- It is intended for use in a domestic setting only.

♥ **General Instructions**

OHS Body Scale ESSENCE applies SENSE ON technology. It's not necessary to turn on or turn off the scale, just stand on the scale for measurement. It is delicate and trendy, convenience for using.

♥ **Device Components**

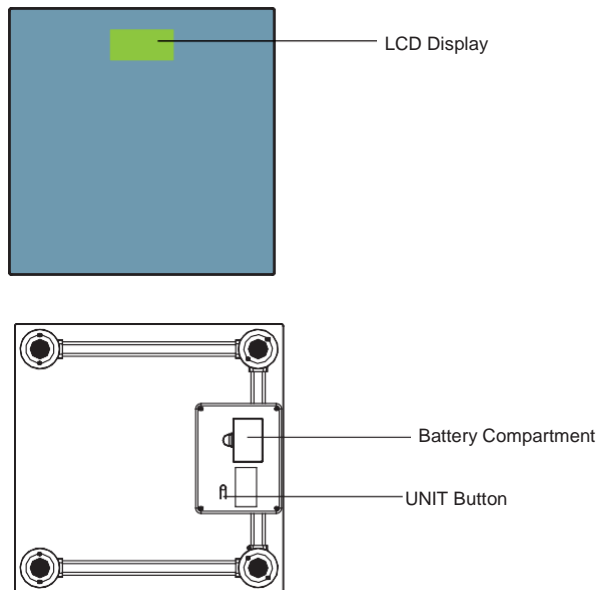

♥ **Function Indication**

- ✧ UNIT Button: Press "UNIT Button" to select desired unit in weighing mode.
or
Press "UNIT Button" to turn on the scale.

♥ **List**

1. Body Scale ESSENCE
2. 1 x CR2032 battery (3V)
3. User Manual

♥ **LCD Display**

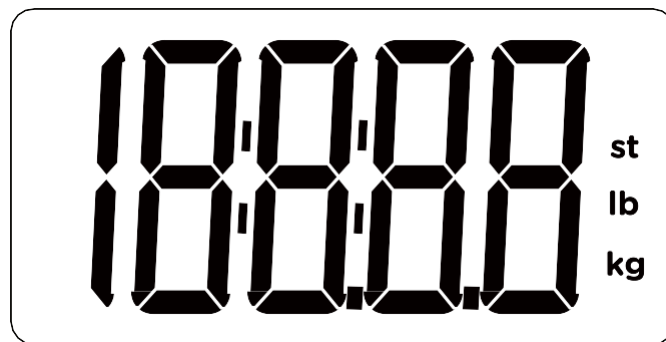

Symbol	Description
kg	Kilogram
lb	Pound
st lb	

♥ Take out the Insulating Strip

- Open the battery door in the back of the scale.
- Take out the insulating strip along the direction as the picture shown on the right.
- Close the battery door and wait until the digits "0.00kg" are shown on the LCD.

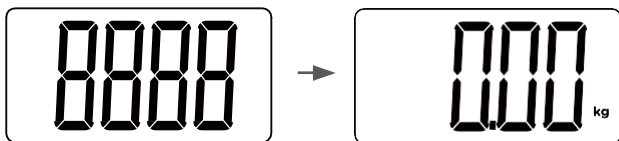
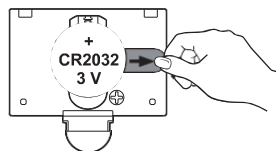

♥ Replace the Battery

- Open the battery door in the back of the scale.
- Insert the battery (1 x CR2032) into the battery compartment according to the polarity indications marked inside the compartment.
* The digits 8888 will be shown on the LCD.
- Close the battery door and wait until the digits "0.00kg" are shown on the LCD.

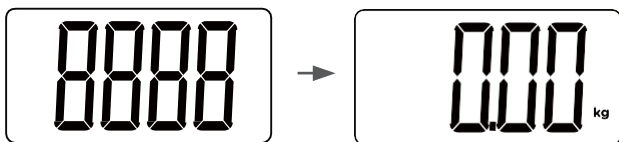

⚠ CAUTION

- When the symbol "Lo" appears, the device will power off in about 4s. Then replace with a new battery. Worn batteries are hazardous waste. Do NOT dispose of them together with the household garbage.
- Please refer to the local ordinances and recycling instructions regarding disposal of the worn batteries.
- To achieve the best performance and protect your scale, please use the authorized/specified batteries.

♥ Select Measurement Unit

With battery correctly installed, press "UNIT" button in the back of the scale to select measurement unit. The default measurement unit is "Kilogram". You may press "UNIT" button to choose among kilogram, stone and pound.

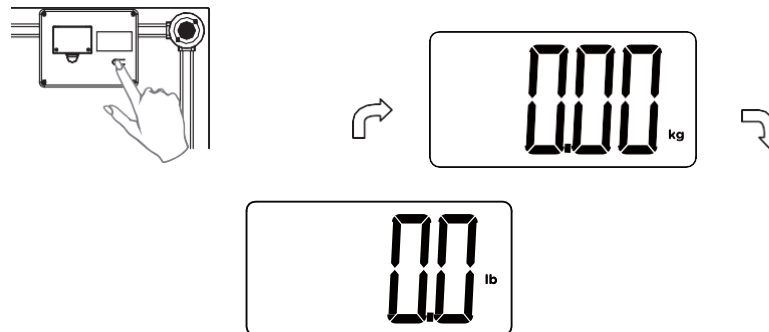

⚠ CAUTION

Please put the scale on the flat hard ground when finishing the unit selection. Wait for a few seconds, then you may start measuring according to the measuring procedure below. If there is not any operation in weighing mode, the scale will turn off automatically after about 10s.

♥ Initializing Your Scale

1. Press the platform center and remove your foot
or
Press UNIT button to turn on the scale.
2. "0.00" will be displayed.



3. The scale will switch off and is now ready for use.
This initialization process must be repeated if the scale is moved.
At all other times step straight on the scale.

♥ Start Measuring



1. Place the scale flat on a hard surface.
2. Step onto the platform and stand still until the weight is stable, the unit on the LCD blinks twice, then the weight is locked.



3. The measuring result is displayed for about 10 seconds, and then it will turn off.

Note: If there is no operation in 10 seconds when the scale is on, it will turn off automatically.

♥ Error Prompt

Error	Description	Solution
	Overload. The device will power off.	Stop using this scale for measurement.
	Low Battery. The device will power off.	Replace with a new battery. Please purchase the correct batteries for replacement.

♥ Specifications

Product Name	Body Scale
Dimension	Scale: 300x300x23.5mm (Approximately)
Net Weight	Approximately 1.51kg (Including the cell)
Display	Digital LCD V.A.: 72x35mm (Approximately)
Measurement Unit	Kilogram / Pound
Measurement Range	5kg to180kg / 11lb to 397lb
Division	0.05 kg/0.1lb
Accuracy	50kg: ±0.3kg; 100kg: ±0.4kg; 150kg: ±0.5kg; 180kg: ±0.7kg;
Working Environment	Temperature: 5°C to 40°C Relative Humidity: ≤90% RH Atmospheric pressure: 86kPa to 106kPa
Storage Environment	Temperature: -20°C to 60°C Relative Humidity: ≤90% RH Atmospheric pressure: 50kPa to 106kPa
Power Source	3V (1 x CR2032 Battery)
Auto-ON	SENSE ON technology
Auto-OFF	The scale will turn off after about 10s if there is no operation.
Accessories	1. 1 x CR2032 Battery 2. User Manual
Mode of Operation	Continuous Operation

About the Accuracy of This Product

- This product passes strict inspection before delivery and therefore its accuracy is guaranteed by the manufacturer. Please refer to the above table for the descriptions on accuracy.
- This product is specially designed for body scale as well as weight measurement. It should NOT be used by anyone during the process of transaction for verification of goods' weight.

♥ Maintenance

When carrying out usual maintenance, please ensure practice of the following Do's and Don'ts:

- DO use a dry soft cloth to wipe the dust.
- DO use a wet soft cloth, dipped into water and wrung out, to wipe the dirt. Then use a dry soft cloth to dry up the device.
- DON'T wash the device with water or immerse it in water.
- DON'T use propellant, abrasive or other chemicals to wipe the dirt to avoid discolor or malfunction.
- DON'T disassemble this device. If you have any problems, please contact OHS.
(Please refer to Warranty for contact information)

♥ Warranty

- OHS warrants its products free of defects in materials and workmanship in normal use for a period of TEN years from the date of retail purchase.
- This warranty does NOT cover damages caused by misuse or abuse, including but not limited to:
 - Failure caused by unauthorized repairs or modifications;
 - Damage caused by shock or drop during transportation;
 - Failure caused by improper operation inconsistent with the instructions stated in this user manual;
 - Malfunction or damage from failure to provide the recommended maintenance;
 - Damage caused by improper use of power supply.
- Should this device require maintenance (or replacement at our option) under warranty, please deliver the original package to OPTIMA HOME SCALES prepaid. Please return the store receipt (with the retail purchase date) and a note with reasons to return on it as well.

OPTIMA HOME SCALES
PO Box 1526, Cumming GA 30028 UNITED STATES
P: 888-688-4833
ohs@optimascale.com
www.optimahomescales.com

♥ EMC Guidance

1. MEDICAL ELECTRICAL EQUIPMENT needs special precautions regarding EMC and needs to be installed and put into service according to the EMC information provided in the ACCOMPANYING DOCUMENTS.
2. Wireless communications equipment such as wireless home network devices, mobile phones, cordless telephones and their base stations, walkie-talkies can affect this equipment and should be kept at least a distance $d = 3,3$ m away from the equipment. (Note. As indicated in Table 6 of IEC 60601-1-2:2007 for ME EQUIPMENT, a typical cell phone with a maximum output power of 2 W yields $d = 3,3$ m at an IMMUNITY LEVEL of 3 V/m)